

Fiche technique UT-3000FB / Technical sheet UT-3000FB

Application	Résidentielle, Residential
Usage	Léger—Light duty
Norme / Standard	Conforme—Complies with ANSI/BHMA A156.14 Grade 1

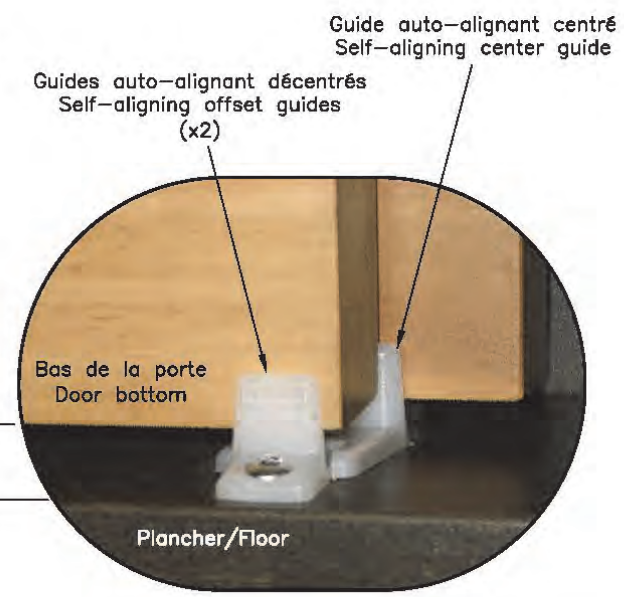
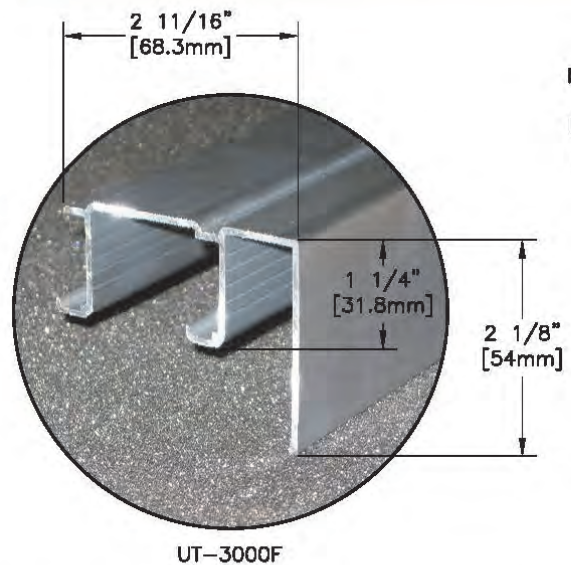
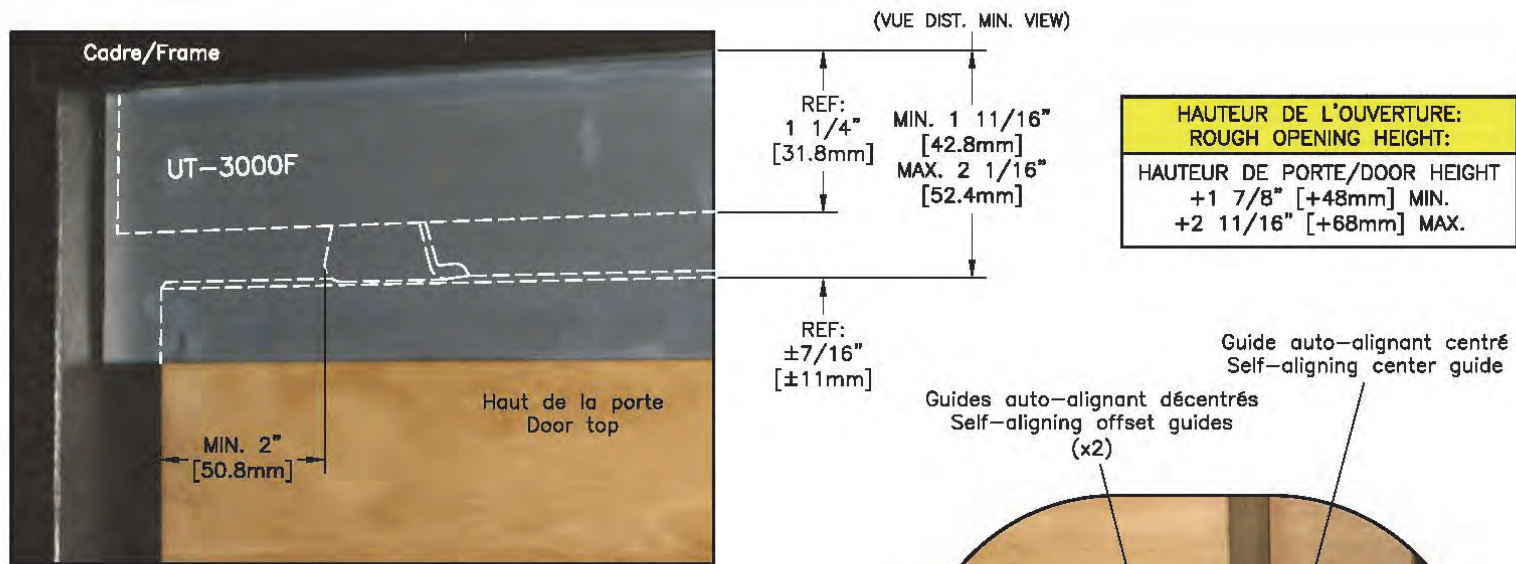

Pour 2 portes/For 2 doors 3/4" ou/or 1 3/8" de/of 60 Livres/Pounds (25Kg) Max.

Architectural
UNIQUE

Votre satisfaction, notre fierté!

Tél.: 514 351-5454 / Fax: 514 351-5554
uniqueproduitarchitectural.com

Systèmes
UNITRACK
Systems

UT-3000FB









Dessin de référence drawing

DESSIN / DRAWING No: REF-UT3000FB

DATE: 16/05/2014

PAGE: 1/1

CE DESSIN EST LA PROPRIETE DE PRODUITS ARCHITECTURAUX UNIQUE INC. TOUTE REPRODUCTION EST STRICTEMENT INTERDITE SANS CONSENTEMENT ECRIT.
THIS DRAWING IS THE PROPERTY OF UNIQUE ARCHITECTURAL PRODUCTS INC. ANY REPRODUCTION WITHOUT WRITTEN CONSENT IS STRICTLY PROHIBITED.

Liste des pièces ensemble UT-3000FB / Parts list UT-3000FB		
Nom / Name	Image / Picture	Quantité / Quantity
Rail UT-3000F Track		1
Chariot UT-3010B Hanger		2
Chariot UT-3015B Hanger		2
Guide décentré auto-alignant UT-3055 Self-aligning offset guide UT-3055		2
Guide centré auto-alignant UT-3050 Self-aligning center guide UT-3050		1
Rondelle de blocage dentée Tooth washer		8
Vis #10x3/4" Screw		16
Vis #8x3/4" Screw		7

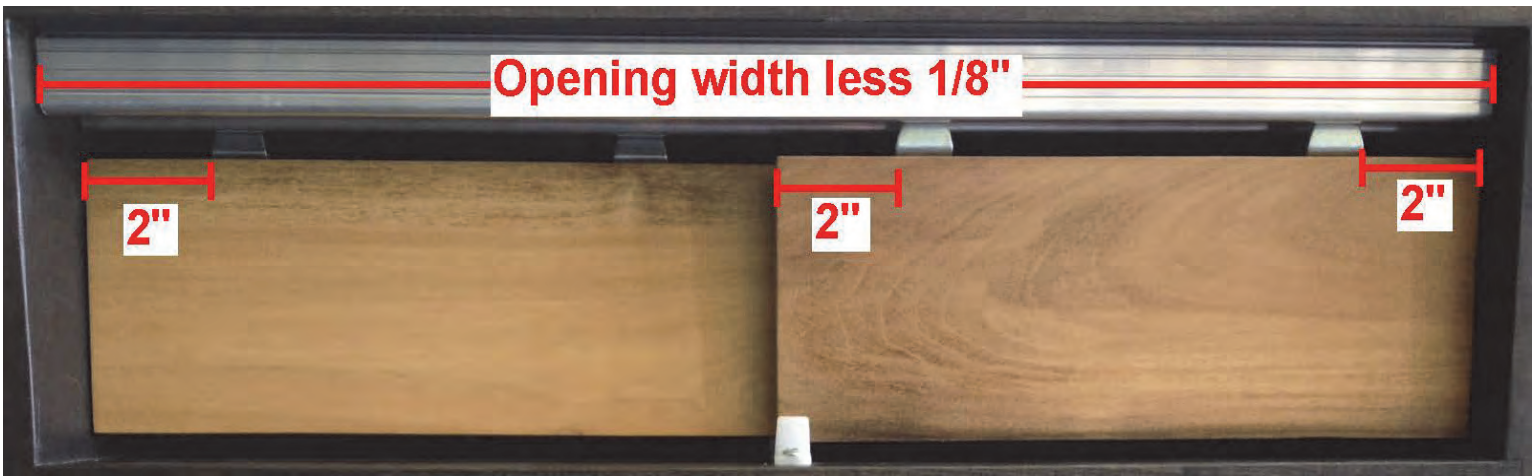

1-Cut rail $\frac{1}{8}$ " LESS than the TOTAL opening width and screw the rail into the opening's header.



2-Install the hangers on the rear of the door at 2" from the end of each door using the slotted holes. Use #10 x $\frac{3}{4}$ " screw and toothed washer, 2 per hanger. To allow a maximum adjustment of the door, set hangers against the top of the door and fasten screws into upper part of the slot. Do not tighten screws, to allow vertical adjustment.

3-Always begin the installation of the doors with the rear door. For $1\text{-}\frac{3}{8}$ " doors, use the $\frac{3}{8}$ " offset hanger on the front door and the $\frac{5}{8}$ " offset hanger on the rear door, and vice-versa for $\frac{3}{4}$ " doors.

4-Tilt the door backwards. Lift door and insert the wheel on the lower part of the track. Tilt the door back to a plumb position. Set the centre guide UT-3050 in position and fix to floor using #8 x $\frac{3}{4}$ " screw, so as to keep door plumb. Repeat same for front door. Set offset guide UT-3055 in position and fix to floor using #8 x $\frac{3}{4}$ " screw, keeping door plumb. Finally, set offset guide UT-3055 behind rear door and fix to floor using #8 x $\frac{3}{4}$ " screw.



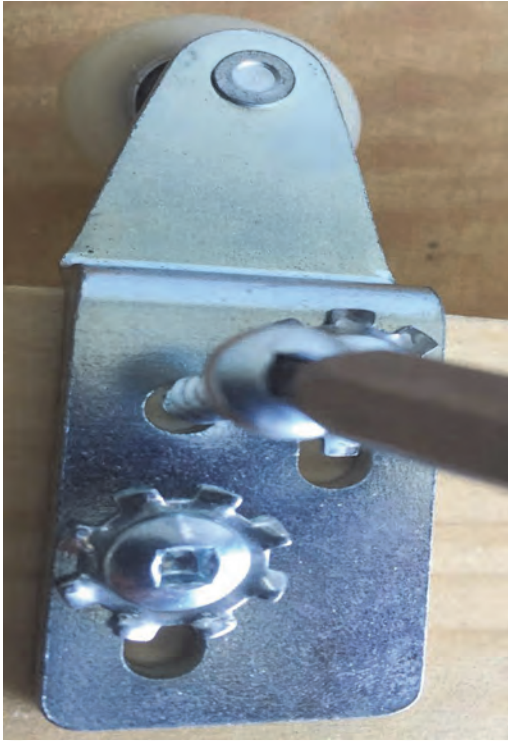

5-Make final adjustments for door height. Tighten screws in slotted holes and use #8 x 3/4" screws in round holes to fix hangers in place.



**HAUTEUR DE L'OUVERTURE:
ROUGH OPENING HEIGHT:**
HAUTEUR DE PORTE/DOOR HEIGHT
+1 7/8" [+48mm] MIN.
+2 11/16" [+68mm] MAX.

Note: If using hollow core doors, avoid cutting top edge of doors, so as to have enough material to screw hangers to top of door.

Parts list for UT-3000B and UT-3000FB series		
Name	Picture	Quantity
UT-3000 or UT-3000F rail		1
Hanger UT-3010B		2
Hanger UT-3015B		2
UT-3055 Offset self-aligning guide		2
UT-3050 Center self-aligning guide		1
Tooth washer		8
Screw #10x3/4"		16
Screw #8x3/4"		7